

AQUILLA_IP66 LED HIGH BAY

Crompton



AQUILLA LED highbay lighting fixtures are powerful, energy-efficient lighting solutions designed for high-ceiling environments like warehouses, factories, large scale industries and large retail spaces. They typically feature LED technology, providing bright illumination while consuming less energy compared to traditional lighting options. These highbays offer long lifespans, low maintenance requirements, superior illumination & distribution and customizable options, thereby making industries a safer place to work

AQUILLA_LED HIGH BAY LIGHT FAMILY

Crompton

P

Product Application



Warehousing



Large Retail Space

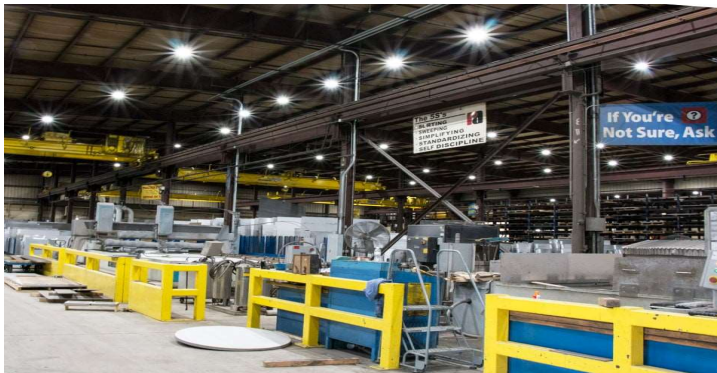

Factories



Industries

AQUILLA_LED HIGH BAY LIGHT FAMILY

Crompton

Product_Main Features



Efficacy : >120, 130 & 150 LM/W
LED Life Span : 50000 Hrs



5 KV Driver Surge Protection
+
10KV External Surge Protection



IP Lens



IP66

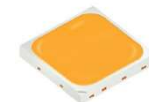

High Power LED



BIS approved IP66
Potted Driver



Safety chain for
Extra precaution



Operating Temp
-10°C to 45°C

- PF > 0.95
- Electrical Class I



Wattages:

80/100/120/150/

180/200/250W



AQUILLA_LED HIGH BAY LIGHT FAMILY

Crompton

P

Product specifications_ Mechanical



Robust :

- Pressure die cast aluminium alloy housing with excellent surface finish
- Crompton brand laser printed for traceability till life
- Superior heat sink for better heat dissipation & Luminaire life

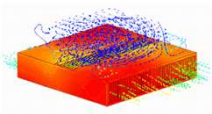

IP lens

- Superior finish & uniformity
- UV stabilised Non yellowing type
- Highbay mounting via Heavy Duty Eyebolt
- Additional Safety Chain provided for for extra precaution



Impact Resistance –

- impact of 5.0 Joules on each side.
- This is equivalent to the impact of 1.7 Kg mass dropped from 300mm above the impacted surface

IK08



AQUILLA_LED HIGH BAY LIGHT FAMILY

Crompton

P roduct specifications_ Electrical



- **Potted driver:** IP66 BIS approved (Electrical safety as per IS 15885)
- Long lasting trouble free service life



High surge protection :

- 5KV inbuilt + 10KV SPD



- PF > 0.95
- Electrical Class 1



- Wide input voltage range 120- 270V AC
- High low cutoff with Auto recovery feature
- High Voltage 440V withstand for 8 Hours



- Operating Temp -10°C to 45°C



Wattages



:80/100/120/150/

180/200/250W

AQUILLA_LED HIGH BAY LIGHT FAMILY

Crompton

Product specifications_ Photometric



Efficacy :
120 LM/W 130 LM/W 150 LM/W
L70 life span : 50000 Hrs



High Efficiency Long Life High Power
Premium category LED package



CCT – 5700K/ 3000K as per ANSI

CRI \geq 70



High Quality Polycarbonate Cover with integrated
Lens with 60° Beam Angle for uniform light
distribution



Superior Illumination

Uniform Distribution

Enhanced Comfort

AQUILLA_LED HIGH BAY LIGHT FAMILY

Crompton

Product Details_ TDS & Codes

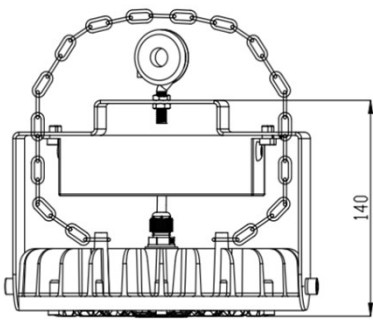

80W

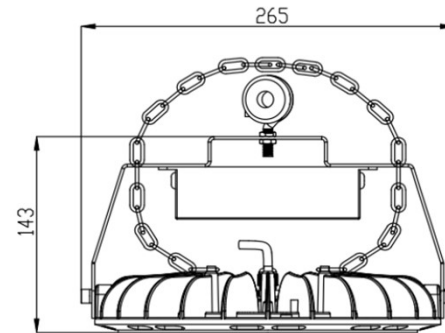
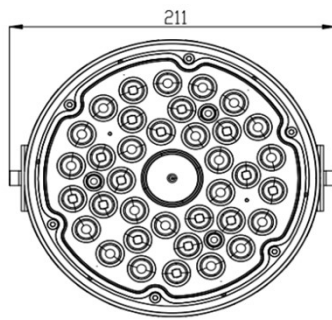

100W

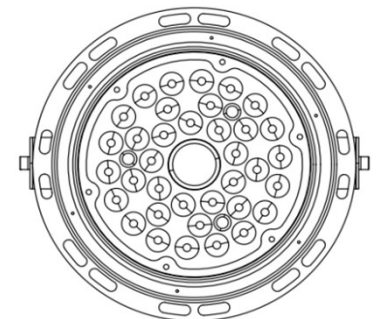

Rated wattage	Order Code	Product description	Outer Case lot
80W	CLI300412-M2	CIP-323-80-57-60D-HL2-LM-NGG	8 Nos
80W	CLI300411-M2	CIP-323-80-57-60D-HL3-LM-NGG	8 Nos
80W	CLI300411-E5	CIP-323-80-57-60D-HL5-LM-NGG	8 Nos
100W	CLI300422-M2	CIP-324-100-57-60D-HL2-LM-NGG	4 Nos
100W	CLI300421-M2	CIP-324-100-57-60D-HL3-LM-NGG	4 Nos
100W	CLI300421-E5	CIP-324-100-57-60D-HL5-LM-NGG	4 Nos

AQUILLA_LED HIGH BAY LIGHT FAMILY

Crompton

Product Details_ TDS & Codes

Rated wattage	Order Code	Product description	Outer Case lot
120W	CLI301712-M2	CIP-328-120-57-60D-HL2-LM-NGG	2 Nos
120W	CLI301710-M2	CIP-328-120-57-60D-HL3-LM-NGG	2 Nos
120W	CLI301710-E5	CIP-328-120-57-60D-HL5-LM-NGG	2 Nos
150W	CLI301722-M2	CIP-329-150-57-60D-HL2-LM-NGG	2 Nos
150W	CLI301720-M2	CIP-329-150-57-60D-HL3-LM-NGG	2 Nos
150W	CLI301720-E5	CIP-329-150-57-60D-HL5-LM-NGG	2 Nos

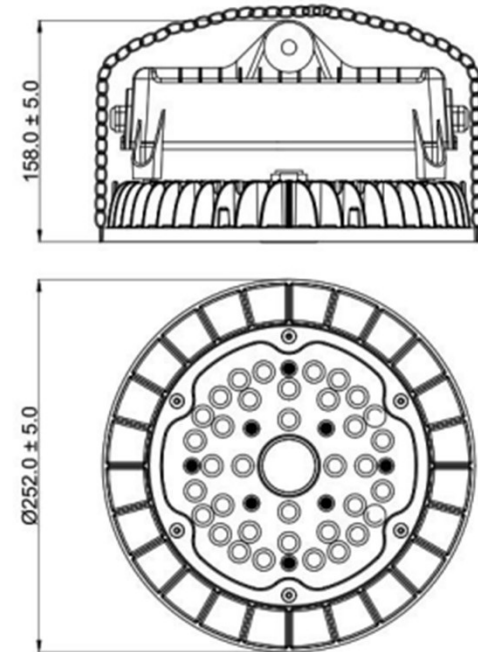

AQUILLA_LED HIGH BAY LIGHT FAMILY

Crompton

Product Details_ TDS & Codes

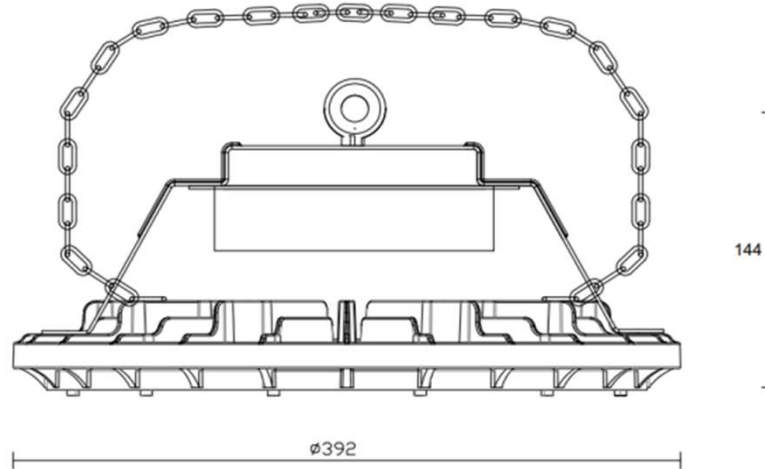

Rated wattage	Rated voltage	Order Code	Product description	Outer Case lot
250W	240V AC	CLI301702-M2	CIP-326-250-57-60D-HL2-LM-NGG	1 No
250W	240V AC	CLI301700-M2	CIP-326-250-57-60D-HL3-LM-NGG	1 No

AQUILLA_LED HIGH BAY LIGHT FAMILY

Crompton

P Product Details_ Photometry

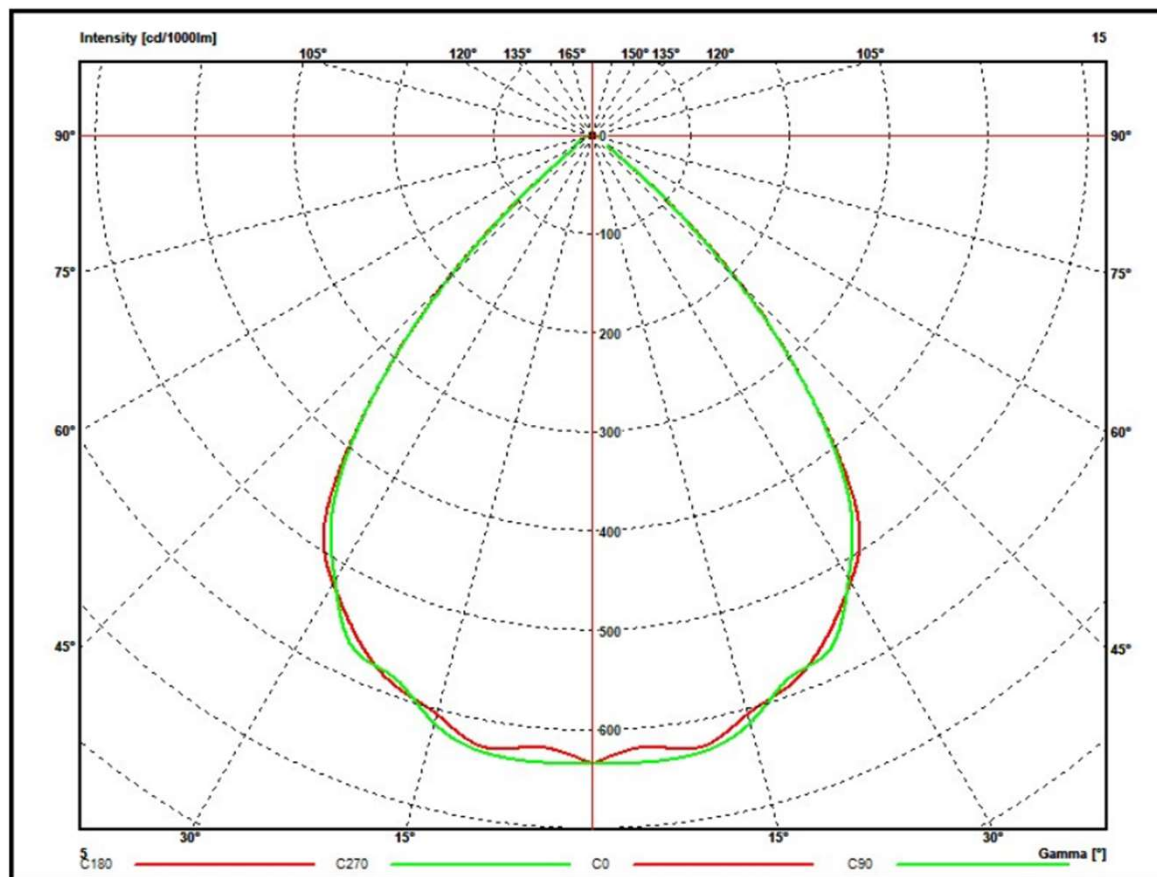

AQUILLA_LED HIGH BAY LIGHT FAMILY

Crompton

P Product_Installation Manual

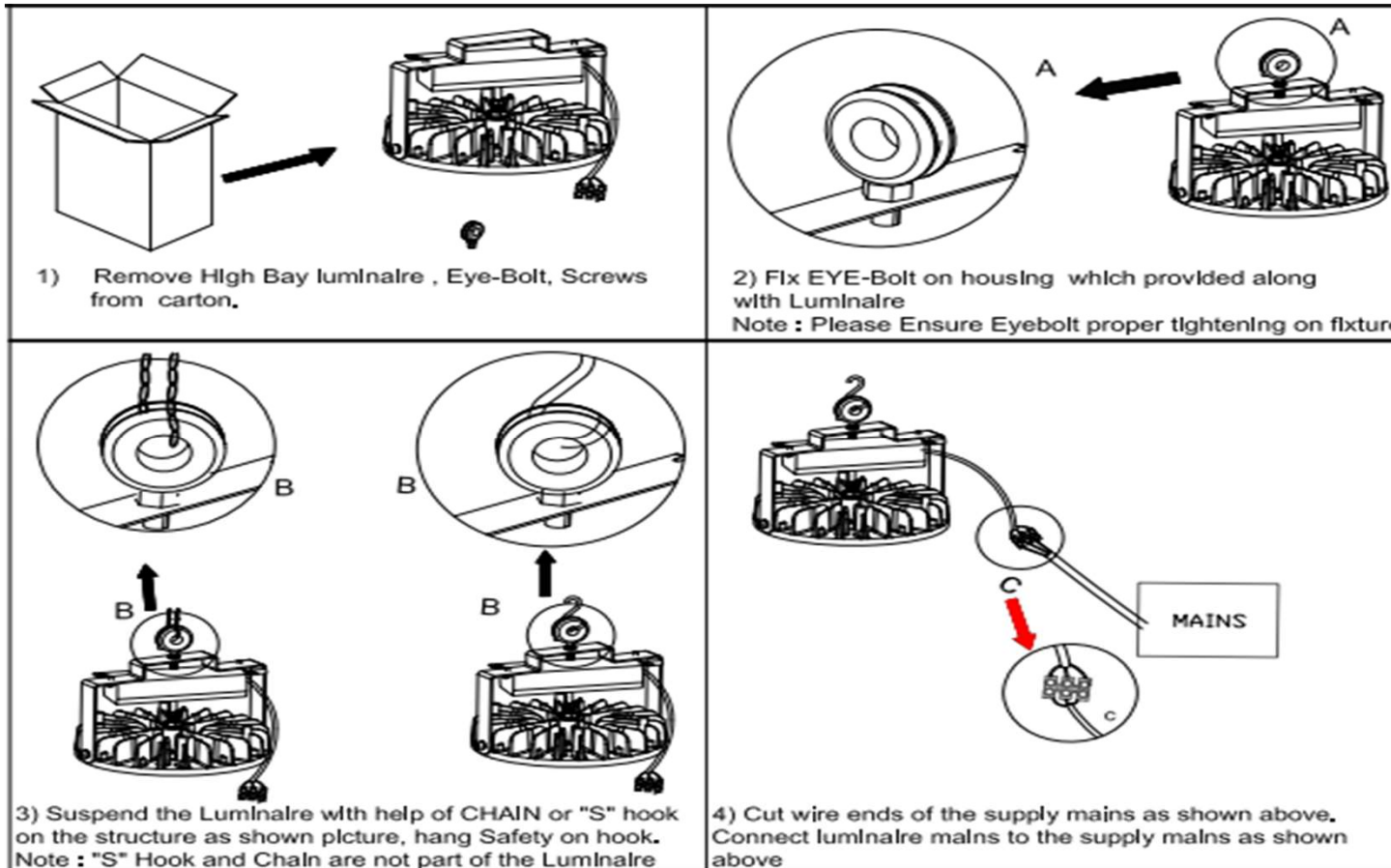

AQUILLA_LED HIGH BAY LIGHT FAMILY

Crompton

Product Compliance



